

# Installation & Maintenance Manual

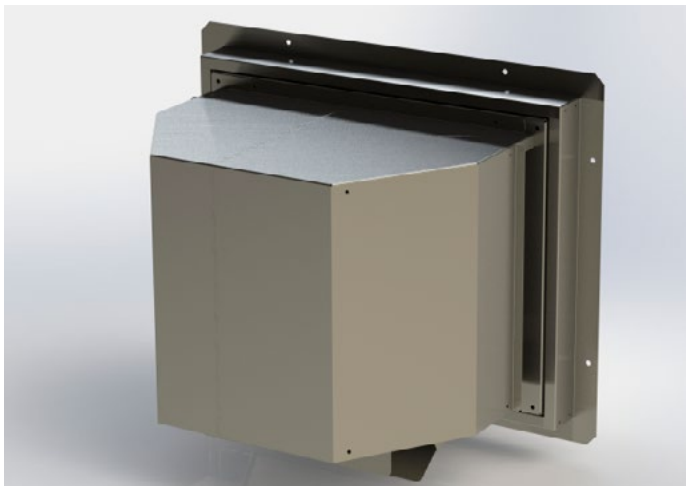

**MONTIGO**  
the art of **fireplaces**

**PVHEX58-300 & PVHEX510-300**  
5/8 and 5/10 External Wall  
Power Vent



- The installation of this fireplace must be done by a qualified and certified gas appliance installer.
- Check local codes and read all instructions prior to installation.

**⚠ WARNING:**  
**FIRE OR EXPLOSION HAZARD**  
Failure to follow safety warnings exactly could result in serious injury, death, or property damage.

- Do not store or use gasoline or other flammable vapors and liquids in the vicinity of this or any other appliance.
- **WHAT TO DO IF YOU SMELL GAS**
  - Do not try to light any appliance.
  - Do not touch any electrical switch; do not use any phone in your building.
  - Leave the building immediately.
  - Immediately call your gas supplier from a neighbour's phone. Follow the gas supplier's instructions.
  - If you cannot reach your gas supplier, call the fire department.
- Installation and service must be performed by a qualified installer, service agency or the gas fitter.

## **⚠ WARNING**

Do not store or use gasoline or any other flammable vapours or liquids in the vicinity of this or any other gas burning appliance. A fire or explosion may occur resulting in serious injury, property damage or death

## **NOTICE**

**Installer:** Leave this manual with the appliance.  
**Consumer:** Retain this manual for future reference.

## **⚠ CAUTION**

Installation and service must be performed by a qualified installer, service agency or the gas fitter.

## **NOTICE**

This power vent is approved for use with Montigo fireplaces only and is certified to ANSI Z21.50 / CSA 2.22 vented gas fireplace standard along with the fireplace

## **⚠ WARNING**

Some materials used in the manufacturing process of this product can expose you to Benzene which is known in the State of California to cause cancer and birth defects or other reproductive harm. For more information go to [www.P65warnings.ca.gov](http://www.P65warnings.ca.gov)

## Safety Alert Key



### DANGER

Indicates a hazardous situation which, if not avoided, WILL result in death or serious injury or property damage.



### WARNING

Indicates a hazardous situation which, if not avoided, COULD result in death or serious injury or property damage.



### CAUTION

Indicates a hazardous situation which, if not avoided, WILL result in minor or moderate injury.

### NOTICE

Addresses practices that are important, but not related to personal injury

## General Information

This installation guide covers installation of the External Power Vent System only. This system is designed to allow installation of gas fireplaces that cannot be done with a standard Direct Vent gas fireplace installation. Only for use on R-Series, R-Series See-Through and RP-Series.

ONLY USE WITH APPROVED FIREPLACES - see fireplace installation manual.

Read through the fireplace's installation & maintenance manual, as it must also be adhered to.

#### Power Cord Harnesses:

- EPVH10 - 10 foot power cord and harness
- EPVH20 - 20 foot power cord and harness
- EPVH30 - 30 foot power cord and harness
- EPVH40 - 40 foot power cord and harness
- EPVH50 - 50 foot power cord and harness
- EPVH60 - 60 foot power cord and harness
- EPVH70 - 70 foot power cord and harness
- EPVH80 - 80 foot power cord and harness
- EPVH90 - 90 foot power cord and harness
- EPVH100 -100 foot power cord and harness



### CAUTION

When cold air enters the warmer building interior, primarily at the air intake end, condensation may occur on the exterior of the flex pipe. To limit this condensation, install insulation over the last 20' of flex pipe. Also, by sloping the last 20'-0" of flex pipe downwards towards the exterior of the building will help eliminate any condensation problems, should they occur. Ensure the termination is securely fastened and sealed to the flex pipe. Fasten the termination to the exterior of the building with water tight sealant and the appropriate fasteners.

### NOTICE

You must read and understand this manual prior to installation, operation or troubleshooting the appliance. Please retain this owner's manual for future reference and maintenance.

## Specifications

	Pipe Dimensions	Maximum Airflow	Speed	Power
PVHEX58-300	5"/8"	300 CFM	2700 RPM	Connect to fireplace control box
PVHEX510-300	5"/10"	300 CFM	2700 RPM	Connect to fireplace control box

# Contents

---

<b>Safety Alert Key</b> .....	<b>2</b>
<b>General Information</b> .....	<b>2</b>
<b>Specifications</b> .....	<b>2</b>
<b>Product Dimensions</b> .....	<b>4</b>
Unit Dimensions .....	4
<b>Installation Locations</b> .....	<b>5</b>
<b>Install</b> .....	<b>6</b>
Installing the Power vent .....	6
Installing the Power vent .....	6
Wiring Diagram .....	8
Wiring Installation.....	8
Capacitor Replacement.....	8
Motor and Capacitor Replacement.....	10
<b>Appendix B: Warranty</b> .....	<b>12</b>

# Product Dimensions

## Unit Dimensions

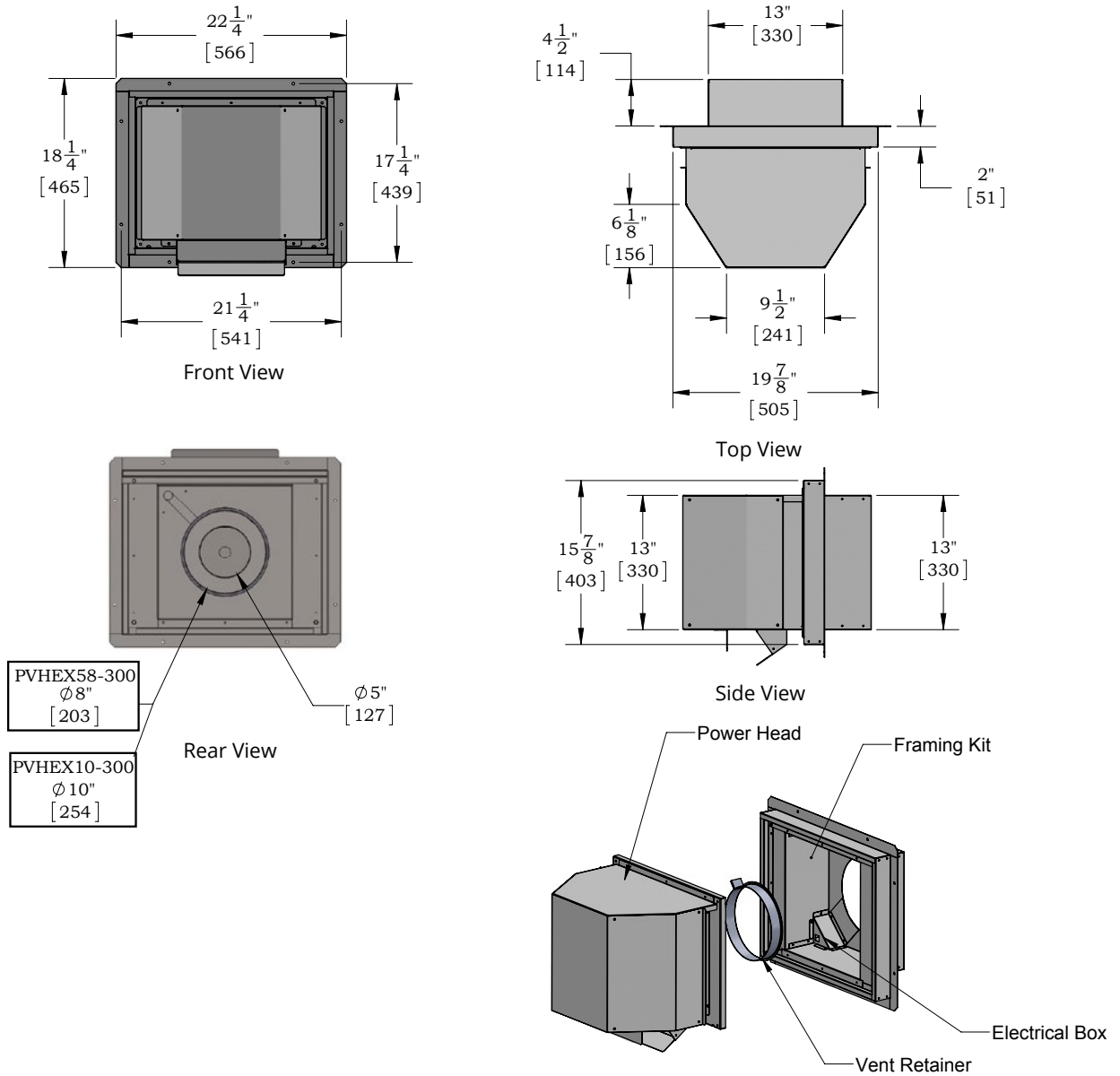
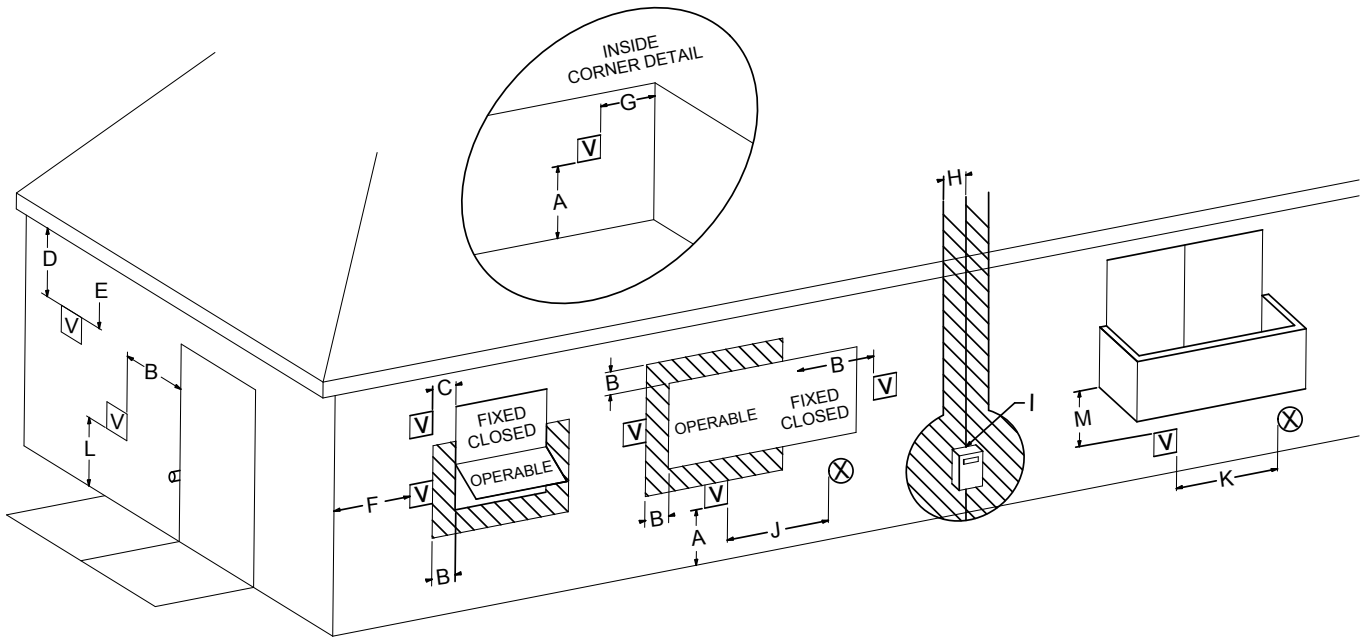

Figure 1. PVHEX58-300 & PVHEX510-300 (Tolerance  $\pm \frac{1}{8}"$ ) [mm]

## Installation Locations



☐ VENTER TERMINAL

⊗ AIR SUPPLY INLET

▨ AREA WHERE TERMINAL IS NOT PERMITTED

	Canadian Installations <sup>1</sup>	US Installations <sup>2</sup>
A= Clearance above grade, veranda, porch, deck, or balcony	12 in (30 cm)	12 in (30 cm)
B= Clearance to window or door that may be opened	6 in (15 cm) for appliances ≤ 10,000 Btuh (3 kW), 12 in (30 cm) for appliances > 10,000 Btuh (3 kW) and ≤ 100,000 Btuh (30 kW), 36 in (91 cm) for appliances > 100,000 Btuh (30 kW)	6 in (15 cm) for appliances ≤ 10,000 Btuh (3 kW), 9 in (23 cm) for appliances > 10,000 Btuh (3 kW) and < 50,000 Btuh (15 kW), 12 in (30 cm) for appliances ≥ 50,000 Btuh (15 kW)
C= Clearance to permanently closed window	<b>B</b>	<b>B</b>
D= Vertical clearance to ventilated soffit located above the terminal within a horizontal distance of 2 feet (61 cm) from the center line of the terminal	15 in (38 cm)	15 in (38 cm)
E= Clearance to unventilated soffit	15 in (38 cm)	15 in (38 cm)
F= Clearance to outside corner	6 in (15 cm)	6 in (15 cm)
G= Clearance to inside corner	15 in (38 cm)	15 in (38 cm)
H= Clearance to each side of center line extended above meter/regulator assembly	3 ft (91 cm) within a height 15 ft. (4.5 m) above the meter/regulator assembly	*
I= Clearance to service regulator vent outlet	3 ft (91 cm)	*

	Canadian Installations <sup>1</sup>	US Installations <sup>2</sup>
J= Clearance to nonmechanical air supply inlet to building or the combustion air inlet to any other appliance	6 in (15 cm) for appliances ≤ 10,000 Btuh (3 kW), 12 in (30 cm) for appliances > 10,000 Btuh (3 kW) and ≤ 100,000 Btuh (30 kW), 36 in (91 cm) for appliances > 100,000 Btuh (30 kW)	6 in (15 cm) for appliances ≤ 10,000 Btuh (3 kW), 9 in (23 cm) for appliances > 10,000 Btuh (3 kW) and ≤ 50,000 Btuh (15 kW), 12 in (30 cm) for appliances > 50,000 Btuh (15 kW)
K= Clearance to a mechanical air supply inlet	6 ft (1.83 m)	3 ft (91 cm) above if within 10 ft (3 m) horizontally
L= Clearance above paved sidewalk or paved driveway located on public property	7 ft (2.13 m) †	*
M= Clearance under veranda porch deck, or balcony	12 in (30 cm) ‡	*

<sup>1</sup> In accordance with the current CSA B149.1, Natural Gas and Propane Installation Code

<sup>2</sup> In accordance with the current ANSI Z223.1/NFPA 54, National Fuel Gas Code

† A vent shall not terminate directly above a sidewalk or paved driveway that is located between two single family dwellings and serves both dwellings.

‡ Permitted only if veranda, porch, deck, or balcony is fully open on a minimum of two sides beneath the floor.

\* For clearances not specified in ANSI Z223.1/NFPA or CSA B149.1, one of the following shall be indicated

a) A minimum clearance value determined by testing in accordance with section 2.23.5, or;

b) A reference to the following footnote:

"Clearance in accordance with local installation codes and the requirements of the gas supplier"

## Install

### Installing the Power vent

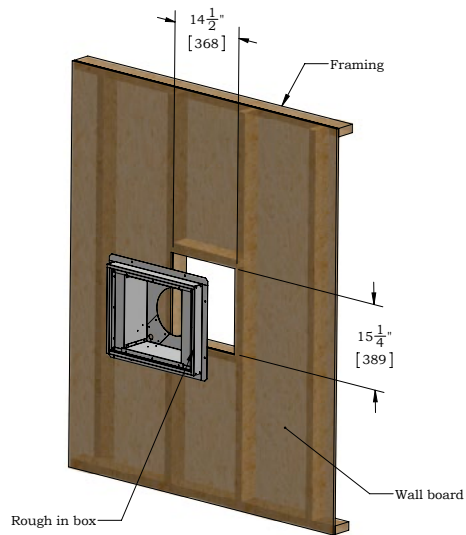

Figure 2. Framing dimensions (combustible material construction)

### Installing the Power vent

1. Unscrew Power Head from rough in Box by unscrewing four screws.



Figure 2.b Unscrewing four screws



Figure 2.c

2. Remove Power head from rough in box.



Figure 2.d

3. Screw rough in box to wall.

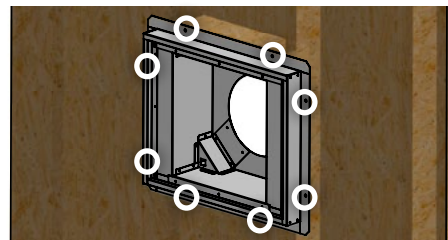

Figure 2.e

4. Remove six screws securing the electrical cover. Remove cover

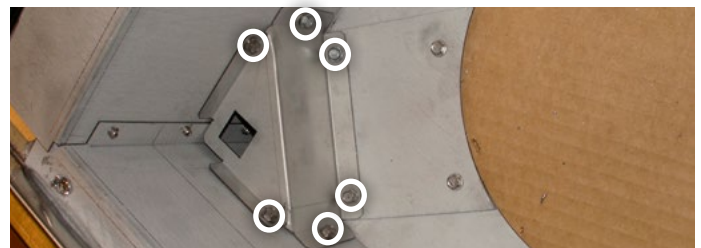

Figure 2.f

5. Remove two screws on the strain relief plate. Remove plate

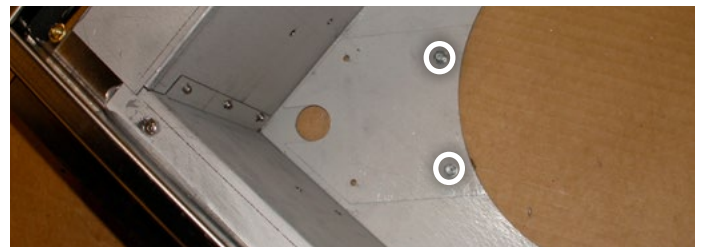

Figure 2.g

6. Take the electrical harness (EPVH-10-100) that will communicate with the Power vent and pass the cable through the slot in the rough box. Make sure the nut for the strain relief is inside the box and the strain relief is outside the box.



Figure 2.h

7. Reinstall the strain relief plate underneath the strain relief nut and screw the strain relief plate down. Then tighten strain relief nut.



Figure 2.i

8. Push the moxex connector through the hole in the electrical cover until it clicks into place.



Figure 2.j

9. Secure the electrical cover back down with the six screws making sure the control cable curls up safely.

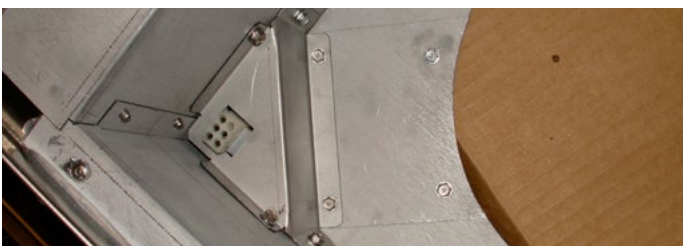

Figure 2.k

10. Pass the vent pipe through the rough in box so it extends 6 1/2 inches into the rough in box.



Figure 2.l

11. Slip the Vent Support Band over the vent so that it sits flush against the back of the rough in box. Tighten the band around the vent so the vent cannot be pushed back through the hole in the rough in box.



Figure 2.m

12. Plug the power cable from the power vent head into the control cable.



Figure 2.n

13. Secure power head onto the rough in box with the supplied 4 screws. Make sure the power head makes good contact with the gasket on the top and sides of the rough in box.

**NOTE:**

Make sure the power cable for the power head does not get pinched or caught. Exhaust chute is pointed towards the ground.

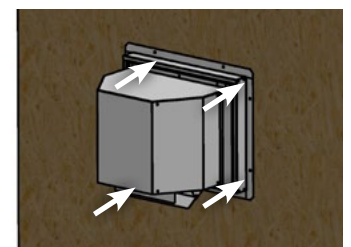
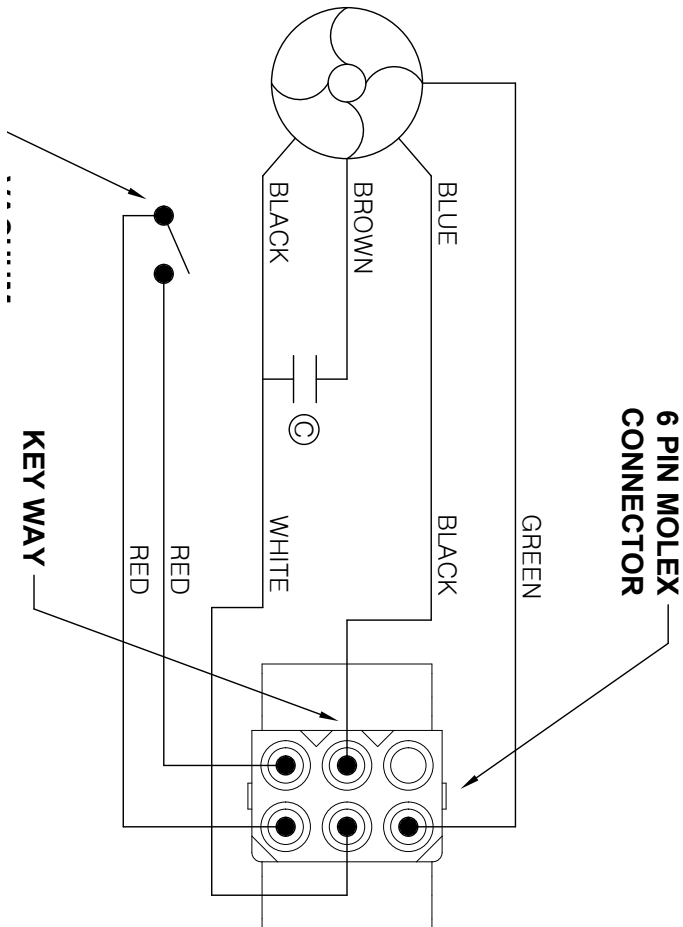

Figure 2.o

## Wiring Diagram



## Wiring Installation

### Conduit & Wiring clearances

Connect the power vent harness as outlined. Connect the wiring to the fireplace as outlined in the schematic shown in figure 4. Ensure that the proper clearances are maintained for the wiring and conduit. When installing the wiring it must never run above the vent run and it must be at least 1" clear of all venting.

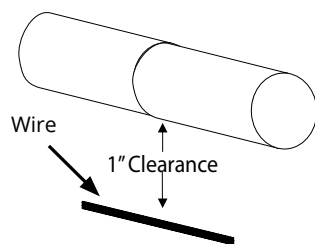

## Capacitor Replacement

1. Turn off power and gas.



Figure 3.a

2. Remove 8 screws securing the outer cover of the power head.

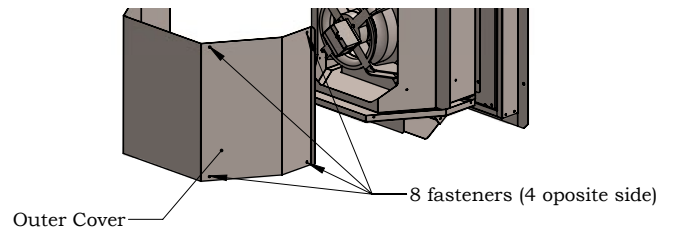

Figure 3.b

3. Cut 3 zap straps securing wiring.

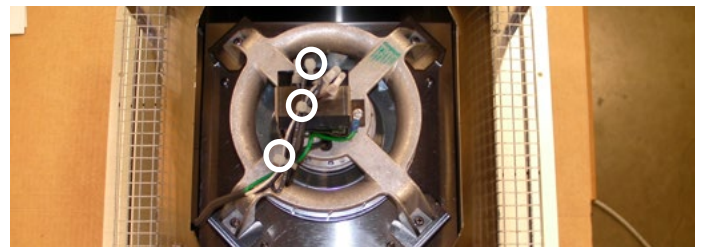

Figure 3.c

4. Cut Brown Wire From Motor.



Figure 3.d



5. Cut white wire from power cable, black wire from motor, and black wire from capacitor.



Figure 3.e

6. Remove ground screw that secures the ground wire and capacitor bracket to the motor. Note: Keep this screw for later use. Dispose of old capacitor.



Figure 3.f

7. Strip all the wires for connection. Using old ground screw secure the ground wire and new capacitor to the motor.

8. Using the large bell connector, connect the white fiber wire from the power cable to the black wire from the motor and the black wire from the capacitor.



Figure 3.g

9. Using the small bell connector, connect the brown wire from the motor to the black wire from the capacitor.



Figure 3.h

10. Using three supplied zap straps, neatly secure wiring. Make sure no wires can get caught in the motor or pinched.



Figure 3.i

11. Check operation and rotation. Motor should spin counter clockwise.

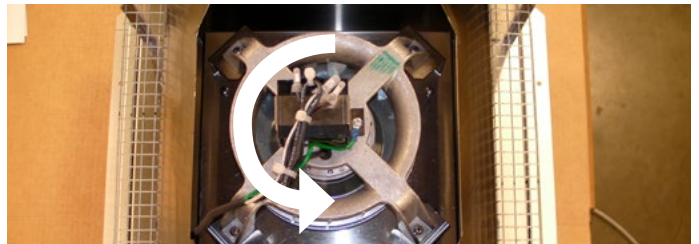

Figure 3.j

12. Secure outer cover with supplied 8 screws.

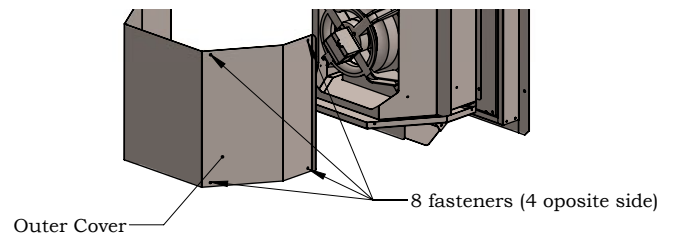

Figure 3.k

## Motor and Capacitor Replacement

1. Turn off power and gas.



Figure 4.a

2. Remove 8 screws securing the outer cover of the power head.

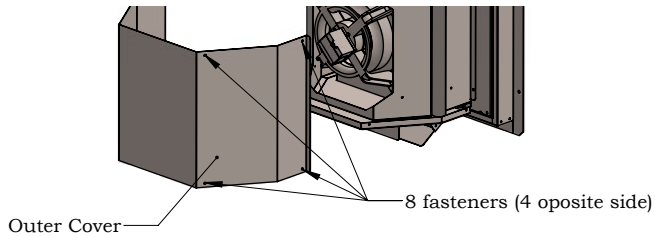

Figure 4.b

3. Cut 3 zap straps securing wiring.

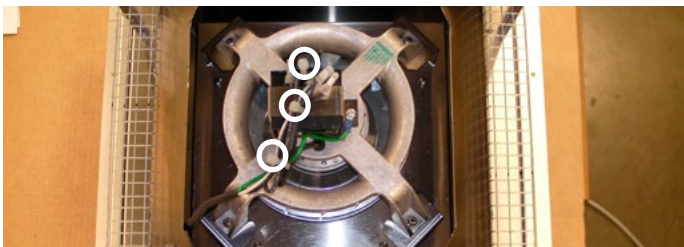

Figure 4.c

4. Cut Brown Wire From Motor.



Figure 4.d

5. Cut white wire from power cable, black wire from motor, and black wire from capacitor.



Figure 4.e

6. Cut the black fiber wire from power cable.



Figure 4.f

7. Remove eight screws securing the motor plate to power head.

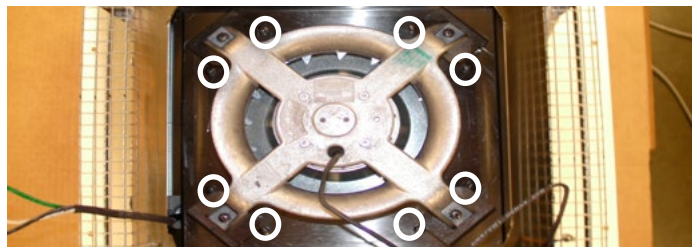

Figure 4.g

8. Lift motor assembly out. Put new motor assembly in.

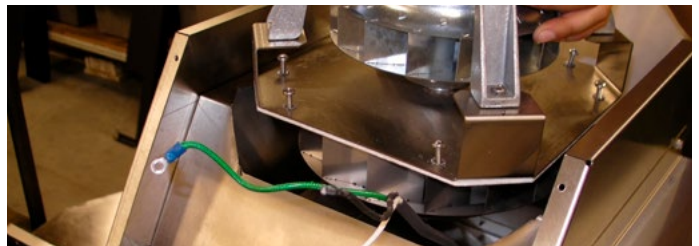

Figure 4.h

9. Secure motor plate with supplied eight screws.

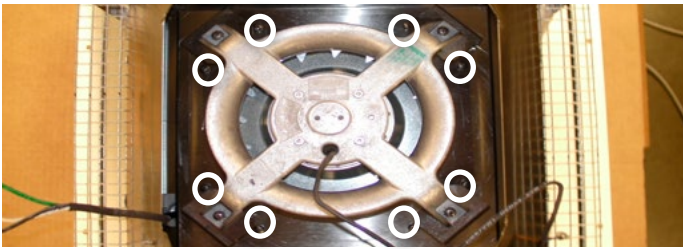

Figure 4.i

10. Attach new capacitor and the ground wire to the ground on the motor. Strip all the wire ends.



Figure 4.j

11. Using a supplied small bell connector, connect the black wire from the power cable to the blue wire from the motor.

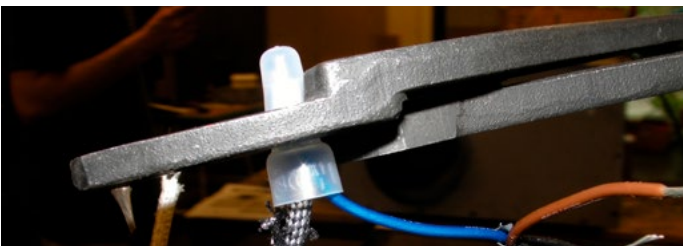

Figure 4.k

12. Using the supplied large bell connector, connect the white fiber wire from the power cable to the black wire from the motor and the black wire from the capacitor.



Figure 4.l

13. Using the other supplied small bell connector, connect the brown wire from the motor to the black wire from the capacitor.

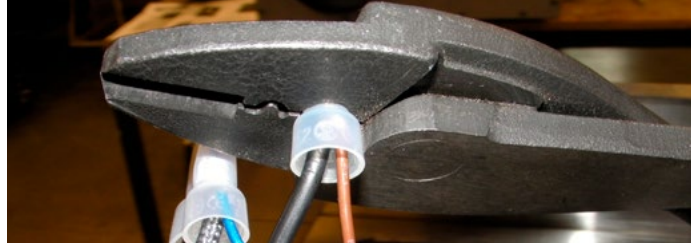

Figure 4.m

14. Using three supplied zap straps, neatly secure wiring. Make sure no wires can get caught in the motor or pinched.



Figure 4.n

15. Check operation and rotation. Motor should spin counter clockwise



Figure 4.o

16. Secure outer cover with supplied eight screws.

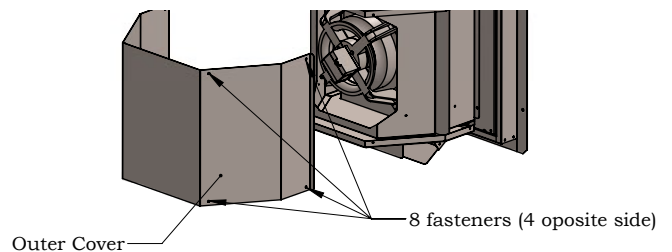

Figure 4.p

## Appendix B: Warranty

### MONTIGO RESIDENTIAL WARRANTY PROGRAM

Empire Comfort Systems, Inc. and/or Empire Comfort Systems Canada, Inc. (collectively referred to herein as "The Companies"), warrants the Montigo gas appliance (referred to herein as 'the appliance') to be free from defects in materials and workmanship at the time of manufacture. The gas appliance and related components are further subject to the terms and conditions set forth below.

This warranty covers the following Montigo product series: **Distinction, Divine & Divine Outdoor (H-Series), Illume (FID Inserts), Phenom (L/P/PL-Series), Exemplar (R/RP-Series), Mahana and DelRay**

Component	Coverage Period	Labor Coverage
Firebox, heat exchanger	15 years	1 year
Main burner	15 years	1 year
Gas control valve and related control components (pilot assembly, spark electrode flame sensors, thermopile)	1 year	1 year
Electrical components (internal blowers, ignition control module, wiring, switches, remote control systems, blower control module, accent bulbs)	1 year	1 year
Firebox media (logset, glass beads, river rocks)	1 year	1 year
Glass (thermal breakage)	1 year	1 year
Plated, painted finishes (including interior reflective glass) *	1 year	1 year
Refractory lining	1 year	1 year
Mesh/Glass safety barriers	1 year	1 year
Power vent termination	1 year	1 year
Montigo terminations*	10 years	1 year
Montigo venting (excluding termination)	15 years	1 year

\* Exterior painted surfaces exempt

### QUALIFICATIONS TO THE WARRANTY

This Warranty only covers gas appliances installed in the United States or Canada.

To receive the benefits of this warranty, the appliance must be purchased, installed and serviced annually by a dealer authorized by The Companies for the warranty to be valid.

The gas appliance must be installed by a licensed professional in accordance with The Companies' installation instructions and local building codes. The warranty on the appliance covers only components manufactured by The Companies. The use of components manufactured or supplied by other manufacturers and used in conjunction with the appliance could create serious safety hazards, may result in the denial of certification by recognized national safety agencies and could violate local building codes. Such use may untimely void this warranty. This warranty does not cover any damages occurring from the use of any components not manufactured or supplied by The Companies.

The appliance must be subjected to normal use. The appliance is designed to burn natural gas (NG) or liquefied petroleum (LP) only. Burning conventional fireplace fuels such as wood, coal or any other solid fuel will cause damage to the appliance, produce

excessive temperatures will result in a fire hazard and void all warranties. This warranty is transferable. The appliance must remain in its original place of installation to be valid.

If the components of the appliance covered by this warranty are found to be defective within the time frame stated (see The Companies investigation of claims), The Companies will, at its option, replace or repair defective components of the appliance manufactured by The Companies at no charge and will also pay for labor costs (in accordance with schedule) incurred in replacing or repairing components. If repair or replacement is not commercially practical, The Companies will, at its sole discretion, fully discharge all obligations under the warranty by refunding the verified dealer purchase price of the appliance, excluding the cost of labor unless the labor is covered by the terms of the warranty.

This warranty covers only parts and labor as provided above. In no case shall the companies be responsible for materials, components or construction, which are not manufactured or supplied by The Companies, or for the labor necessary to install, repair or remove such materials, components or construction. All replacement or repair components will be shipped F.O.B. from the nearest Company factory.

### LIMITATION ON LIABILITY

It is agreed and understood that The Companies sole obligation, and purchaser's exclusive remedy under this warranty, under any other warranty, expressed or implied, or in contract, tort or otherwise, shall be limited to repair, replacement or refund as specified above. The opinion of The Companies with respect to these matters shall be final.

In no event shall The Companies be responsible for any incidental or consequential damages caused by (but not limited to) improper installation, installation by an unqualified or unauthorized installer, accident, lack of regular maintenance, user error, abuse, misuse, Acts of God, power surges, floods, natural disasters, force majeure, defects in its appliance whether such damage occurs or is discovered before or after replacement or repair, and whether or not such damage is caused by The Companies negligence. Some jurisdictions do not allow the exclusion or limitation of incidental or consequential damages, so the above limitation or exclusion may not apply to you. The duration of any implied warranty with respect to the appliance is limited to the duration of the foregoing warranty. Some jurisdictions do not allow limitations on how long an implied warranty lasts, so the above limitation or exclusion may not apply to you.

## Appendix B: Warranty Continued

### EXCLUSIONS TO WARRANTY

Corrosion or rust of any kind due to a lack of maintenance, inadequate combustion air or improper venting and corrosive chemicals/environments, expansion and contraction of metals or minor movements of components causing noise are not covered by this warranty.

Willful misconduct (i.e. use of the appliance with problems known to the purchaser and causing further damages), including unauthorized or self-performed 'fixing' or exploration of the appliance's internal workings will void the warranty.

Appliances on which the serial number has been altered, defaced, removed or made illegible will void the warranty.

Costs incurred for diagnosis, service work, shipping and handling of defective or replacement parts are not covered under this warranty.

The published warranties are not applicable for any equipment manufactured by The Companies that has been sold direct to the consumer via internet or auction websites. The Companies do not endorse, approve or certify any online sale of its products through auction websites, online retailers or any other method of online sales direct to consumers.

### INVESTIGATION OF CLAIMS AGAINST WARRANTY

The Companies reserve the right to investigate any and all claims against this warranty and decide upon method of settlement.

The Companies are not responsible for work done without written consent of The Companies.

The Companies shall in no event be responsible for any warranty work done without first obtaining the Companies written consent.

The Companies employees and dealers have no authority to make any warranties to neither alter this warranty nor authorize any remedies in addition to or inconsistent with those stated within this warranty.

### IF WARRANTY SERVICE IS NEEDED

To make a claim under this warranty, contact your installing dealer or contractor. The installing dealer is responsible for providing service and will contact the companies to initiate warranted parts replacements. In the event the installing dealer is unavailable, contact your nearest authorized Montigo dealer ([www.Montigo.com](http://www.Montigo.com)) or contact Montigo direct at [techsupport@montigo.com](mailto:techsupport@montigo.com). Ensure you have your sales receipt and the model and serial number of your appliance.

### DO NOT ATTEMPT TO DO ANY SERVICE WORK YOURSELF

If you cannot locate the installing dealer, or nearest dealer/distributor, you must notify The Companies in writing.

### USA Offices

6955 Salashan Parkway  
Ferndale WA, 98248  
[techsupport@montigo.com](mailto:techsupport@montigo.com)

### Canadian Offices

27342 Gloucester Way  
Langley, BC V4W 4A1  
[techsupport@montigo.com](mailto:techsupport@montigo.com)

The terms and conditions of this warranty may be altered or amended from time to time without prior notice.

**WARRANTY PERIOD:** Warranty coverage begins on the date of original purchase. In the case of new construction, warranty coverage begins on the date of first occupancy of the dwelling or six months after the sale of the product by an independent, authorized Company dealer/ distributor, whichever occurs earlier.

## Appendix C: Amendment

(Gas Fireplace / Equipment sold in the State of Massachusetts)  
5.08: Modifications to NFPA-54, Chapter 10

- (1) Revise NFPA-54 section 10.5.4.2 by adding a second exception as follows:

Existing chimneys shall be permitted to have their use continued when a gas conversion burner is installed, and shall be equipped with a manually reset device that will automatically shut off the gas to the burner in the event of a sustained back-draft.

- (2) Revise 10.8.3 by adding the following additional requirements:

(a) For all side wall horizontally vented gas fueled equipment installed in every dwelling, building or structure used in whole or in part for residential purposes, including those owned or operated by the Commonwealth and where the side wall exhaust vent termination is less than seven (7) feet above finished grade in the area of the venting, including but not limited to decks and porches, the following requirements shall be satisfied:

1. **INSTALLATION OF CARBON MONOXIDE DETECTORS.** At the time of installation of the side wall horizontal vented gas fueled equipment, the installing plumber or gas fitter shall observe that a hard wired carbon monoxide detector with an alarm and battery back-up is installed on the floor level where the gas equipment is to be installed. In addition, the installing plumber or gas fitter shall observe that a battery operated or hard wired carbon monoxide detector with an alarm is installed on each additional level of the dwelling, building or structure served by the side wall horizontal vented gas fueled equipment. It shall be the responsibility of the property owner to secure the services of qualified licensed professionals for the installation of hard wired carbon monoxide detectors
  - a. In the event that the side wall horizontally vented gas fueled equipment is installed in a crawl space or an attic, the hard wired carbon monoxide detector with alarm and battery back-up may be installed on the next adjacent floor level.
  - b. In the event that the requirements of this subdivision can not be met at the time of completion of installation, the owner shall have a period of thirty (30) days to comply with the above requirements; provided, however, that during said thirty (30) day period, a battery operated carbon monoxide detector with an alarm shall be installed.
2. **APPROVED CARBON MONOXIDE DETECTORS.** Each carbon monoxide detector as required in accordance with the above provisions shall comply with NFPA 720 and be ANSI/UL 2042 listed and IAS certified.
3. **SIGNAGE.** A metal or plastic identification plate shall be permanently mounted to the exterior of the building at a minimum height of eight (8) feet above grade directly in line with the exhaust vent terminal for the horizontally vented gas fueled heating appliance or equipment. The sign shall read, in print size no less than one-half (1/2) inch in size, "GAS VENT DIRECTLY BELOW. KEEP CLEAR OF ALL OBSTRUCTIONS".

4. **INSPECTION.** The state or local gas inspector of the side wall horizontally vented gas fueled equipment shall not approve the installation unless, upon inspection, the inspector observes carbon monoxide detectors and signage installed in accordance with the provisions of 248 CMR 5.08(2)(a)1 through 4.

(b) **EXEMPTIONS:** The following equipment is exempt from 248 CMR 5.08(2)(a)1 through 4:

1. The equipment listed in Chapter 10 entitled "Equipment Not Required To Be Vented" in the most current edition of NFPA 54 as adopted by the Board; and
  2. Product Approved side wall horizontally vented gas fueled equipment installed in a room or structure separate from the dwelling, building or structure used in whole or in part for residential purposes.
- (c) **MANUFACTURER REQUIREMENTS - GAS EQUIPMENT VENTING SYSTEM PROVIDED.** When the manufacturer of Product Approved side wall horizontally vented gas equipment provides a venting system design or venting system components with the equipment, the instructions provided by the manufacturer for installation of the equipment and the venting system shall include:
1. Detailed instructions for the installation of the venting system design or the venting system components; and
  2. A complete parts list for the venting system design or venting system.
- (d) **MANUFACTURER REQUIREMENTS - GAS EQUIPMENT VENTING SYSTEM NOT PROVIDED.** When the manufacturer of a Product Approved side wall horizontally vented gas fueled equipment does not provide the parts for venting the flue gases, but identifies "special venting systems", the following requirements shall be satisfied by the manufacturer:
1. The referenced "special venting system" instructions shall be included with the appliance or equipment installation instructions; and
  2. The "special venting systems" shall be Product Approved by the Board, and the instructions for that system shall include a parts list and detailed installation instructions.
- (e) A copy of all installation instructions for all Product Approved side wall horizontally vented gas fueled equipment, all venting instructions, all parts lists for venting instructions, and/or all venting design instructions shall remain with the appliance or equipment at the completion of the installation.
- (3) After NFPA-54 section 10.10.4.2 add a new section 10.10.4.3 as follows:
- When more than four gas appliances are to be vented through a common gas vent or common horizontal vent manifold, a plan of the proposed vent installation shall be submitted to the Inspector and the serving gas supplier for review and approval.

Extraction from: Massachusetts Rules and Regulations

5.00: Amendments To 2002 Edition Of ANSI Z223.1-NFPA-54



# **PVHEX58-300 & PVHEX510-300**

5/8 and 5/10 External Wall  
Power Vent